

PERFORMER SERIES with Open Burners



*ARROB-424 Shown with 4" Stub Back Hand polished stainless steel finish. Other models available

RANGE TOP FEATURES

- True commercial lift-off burners for easy cleaning.
- 3 sizes of burners to serve your everyday needs: 25,000 BTU (lg), 18,000 BTU (med) and 12,000 BTU (sm)
- Variable infinite flame settings for all open top burners.
- Automatic, electronic ignition ensures re-ignition in the event the flame goes out, even on the lowest burner setting.
- Continuous commercial-grade cast iron grates.
- Porcelainized burner pans catch spills and lift out for easy cleaning.
- Analog controls provide easy, push and turn operation.
- Blue light indicates oven functions.
- Heavy duty metal die-cast satin-stainless knobs with chrome skirts.
- Stainless steel Island Back trim included and installed.
- Front panel switch controls oven lighting for optimal visibility.
- One piece durable precision frame construction oven front.

OVEN FEATURES

- Multiple functions include: Standard Bake, Convection Bake, Infrared Broil and Fan mode
- Convection fan optimizes uniform air flow
- Two chrome racks glide at 6 cooking levels on heavy chrome side supports
- Front panel switch controls oven lighting for optimal visibility

CONVECTION OVEN TECHNOLOGY



Balanced turbulent heat distribution is essential when baking, roasting, and dehydrating food. The American Range convection oven technology features a convection motor and fan to enhance uniform heat distribution throughout the large oven cavity.

The strategic placement of the convection fan ensures consistent heat distribution even when challenged with cooking the largest turkey, ham or roast.

CONVECTION OVEN IS GREEN TECHNOLOGY

The efficient design of the convection oven uses less gas than a standard oven.

Customize with RAL® for the best color that suits your lifestyle.

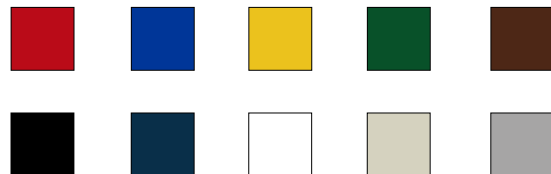

SCALE: NOT TO SCALE

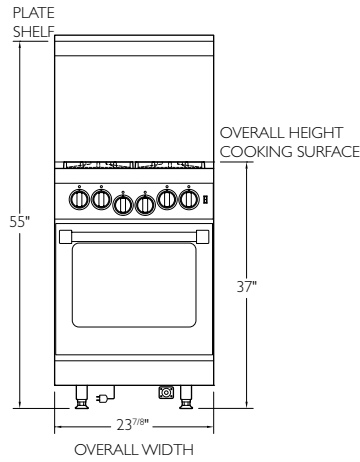

FRONT VIEW

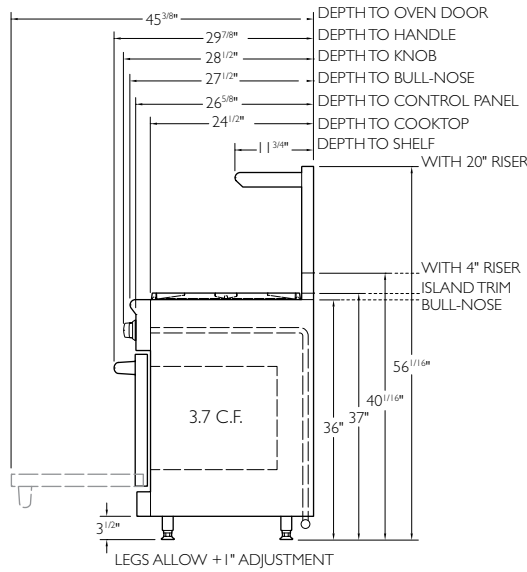

SIDE VIEW

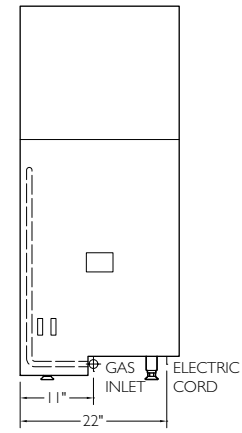

REAR VIEW

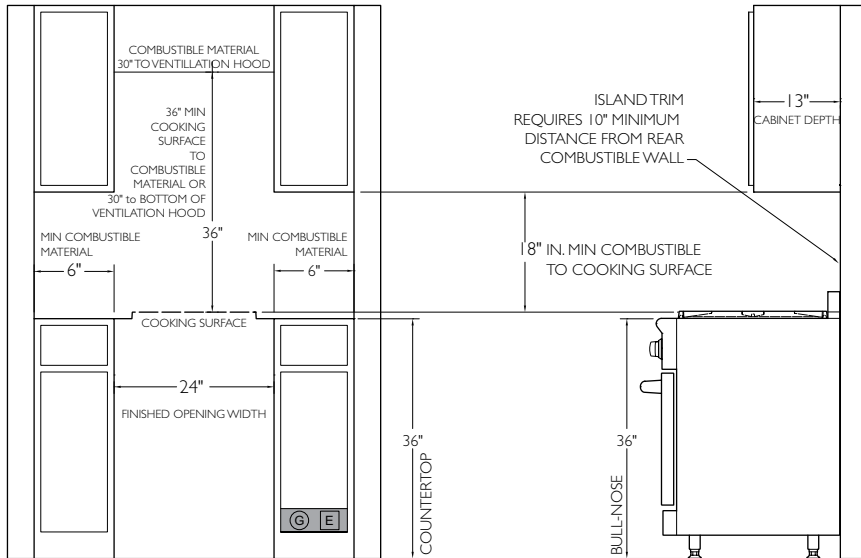

BURNER CONFIGURATIONS

- 25,000 BTU (lg)
- 18,000 BTU (md)
- 12,000 BTU (sm)

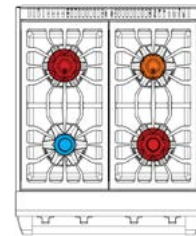

ARROB-424

TOP VIEW

Ⓢ Ⓜ RECOMMENDED LOCATION OF GAS AND ELECTRICAL SUPPLY

ISLAND OR PENINSULA INSTALLATIONS 10" MINIMUM CLEARANCE FROM BACK OF RANGE TO COMBUSTIBLE SURFACE. ISLAND TRIM 0 IN. CLEARANCE TO NON COMBUSTIBLE SURFACE. NO SIDE WALL ABOVE COOKING SURFACE. THIS APPLIANCE SHOULD NOT BE INSTALLED WITH AN AIR CURTAIN OR OTHER TYPE OF VENTILATION SYSTEM THAT BLOWS AIR DOWNWARD TOWARD THE RANGE. SUCH TYPE OF VENTILATION SYSTEM MAY CAUSE IGNITION AND COMBUSTION PROBLEMS WITH THE GAS COOKING APPLIANCE RESULTING IN PERSONAL INJURY OR UNINTENDED OPERATION.

TECHNICAL SPECIFICATIONS

Overall Oven Capacity	3.7 CU. FT.
Oven Dimensions	22 1/2" W x 19" D x 15" H
Surface Burner Rating	25,000 BTU (lg) - 18,000 BTU (md) - 12,000 BTU (sm)
Infrared Broiler	18,000 BTU
Oven Bake Burner	30,000 BTU
Total Gas Connection Rating	ARROB-244 110,000 BTU 4 burners
Gas Supply	7" W.C. Natural, 11" W.C. Propane
Electrical Supply	120 VAC 15 AMP 60 Hz Single Phase
Shipping Weight	340 Lbs

ACCESSORIES & OPTIONS

1" Island Back	ARR24SIB-P	12" Griddle Plate	ARRPGP12-P
1" Island Back (welded)	ARR24IB-P	12" Cutting Board	ARRCUTB12-P
4" Stub Back	ARR244SB-P	Wok Adapter	ARRWOK-P
21" High Back w/ Shelf	ARR-2421HBS-P	Extra Oven Rack 30"	R31012
S/S Leg Caps (2)	ARR2LC-P	Porcelainized Broiler Pan	R31005
S/S Curb Base	ARR24CB-P	Cooktop Cover	ARR24CC-P

***ELECTRICAL REQUIREMENTS**

A grounded three prong plug with proper polarity must be used.

MUST SHIP FROM FACTORY WITH PROPER GAS TYPE.

N=Natural gas **L**= LP Gas. Must provide **N** or **L** after model number for type of gas needed. **Example: ARR-424-L** Must specify elevation if over 2000 ft. when ordering.

* ADJUSTABLE + 1"

A manual gas shut-off valve must be installed external to the appliance, in a location accessible from the front, for the purpose of shutting off the gas supply. This is a vented appliance. To be used in conjunction with a suitable vent hood only.

**The American Range Company continually improves its products and reserves the right to change materials, specifications and dimensions without notice. This unit is manufactured for residential use only.